

VOLVO

Christer Johansson

Investor Relations

Lisbon March 12, 2003

Volvo Group's Positions

Relative size 2001

Heavy duty trucks, > 16 ton

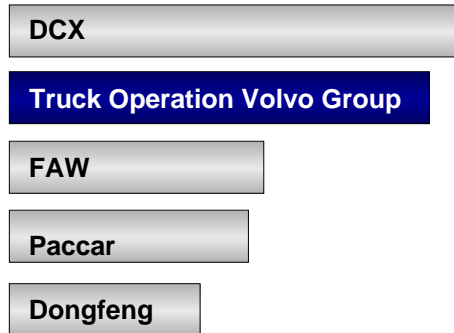

Heavy duty buses, > 12 ton

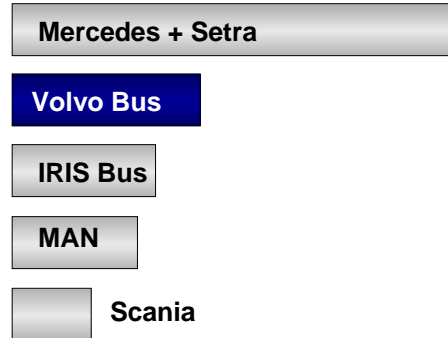

Construction equipment

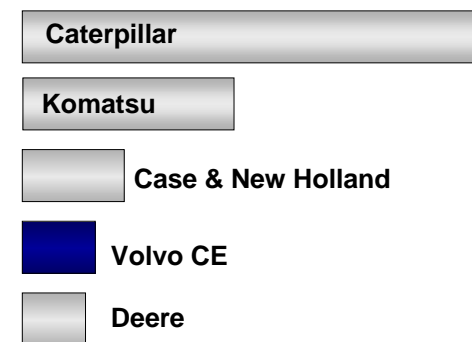

Marine leisure

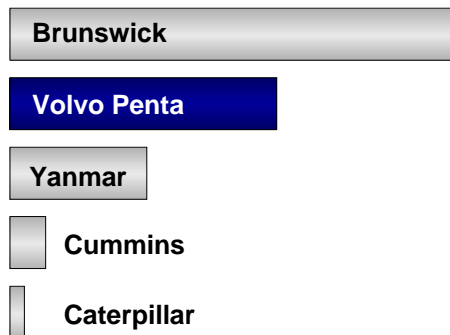

Heavy diesel engines, 9-16 l

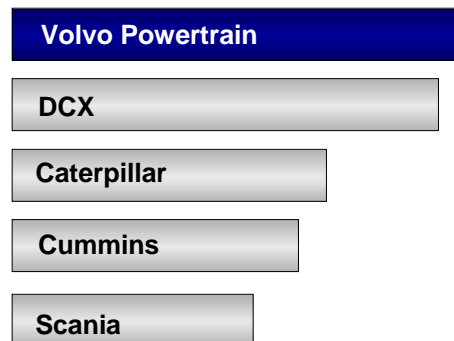

Aero

- World leading in development and production of selected engine components.
- Engine components from Volvo Aero is included in 80% of all larger civil aircrafts.

Heavy Duty Truck Market

Western Europe

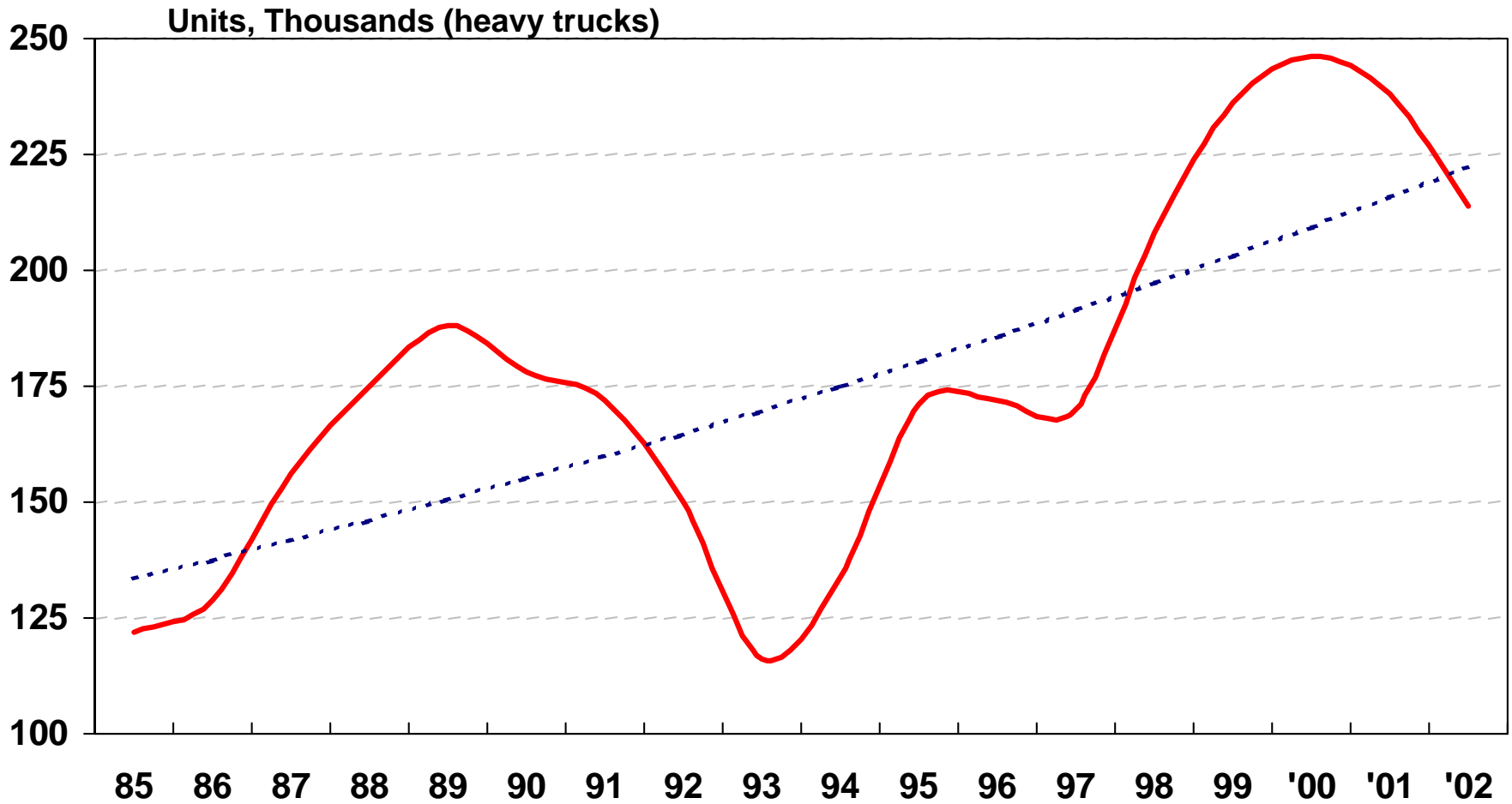

Heavy Duty Truck Market

North America

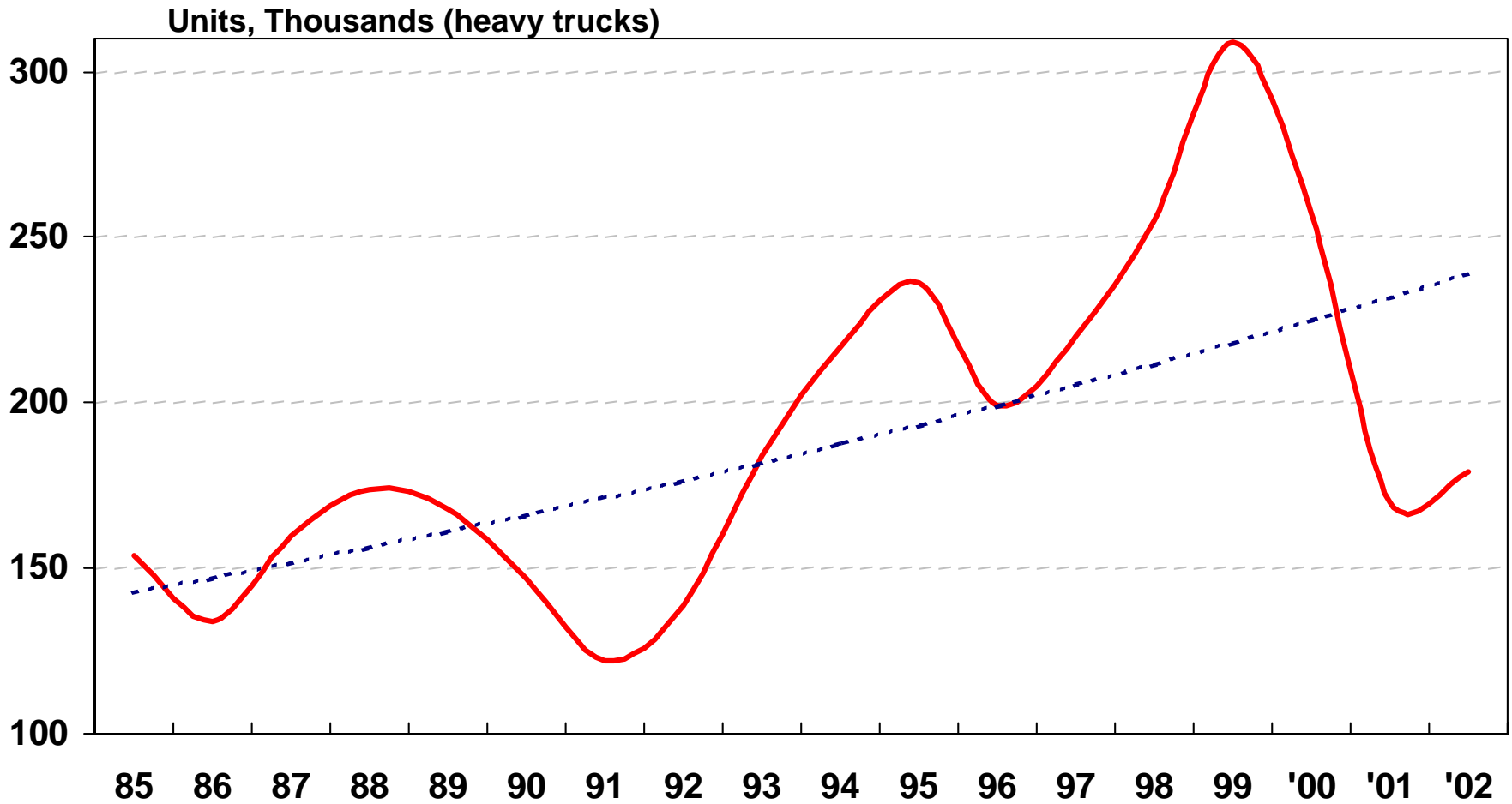

Legislative Demands

Emission Standards

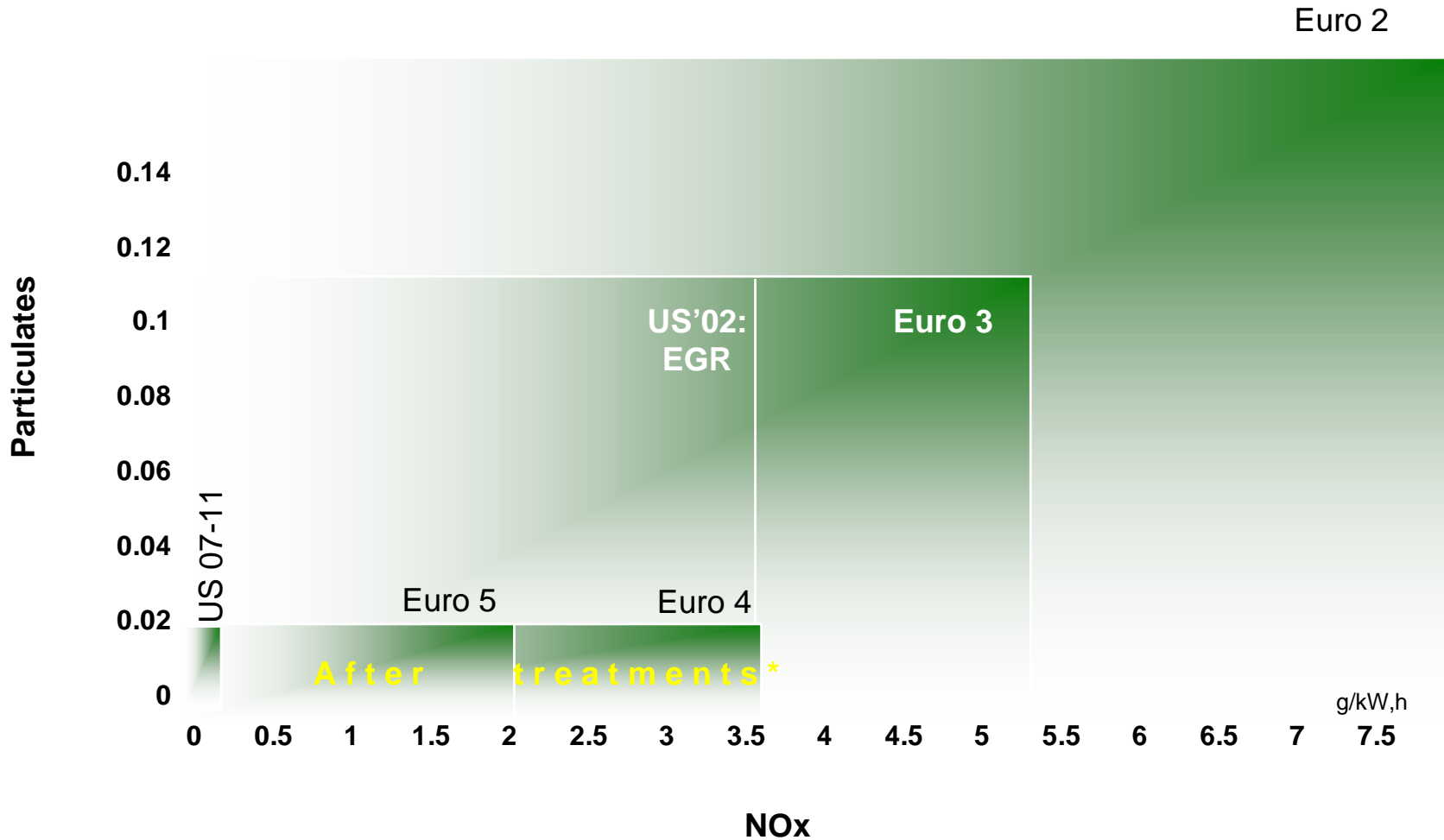

“Global” Market Position

Heavy Duty Engines - 2001 *

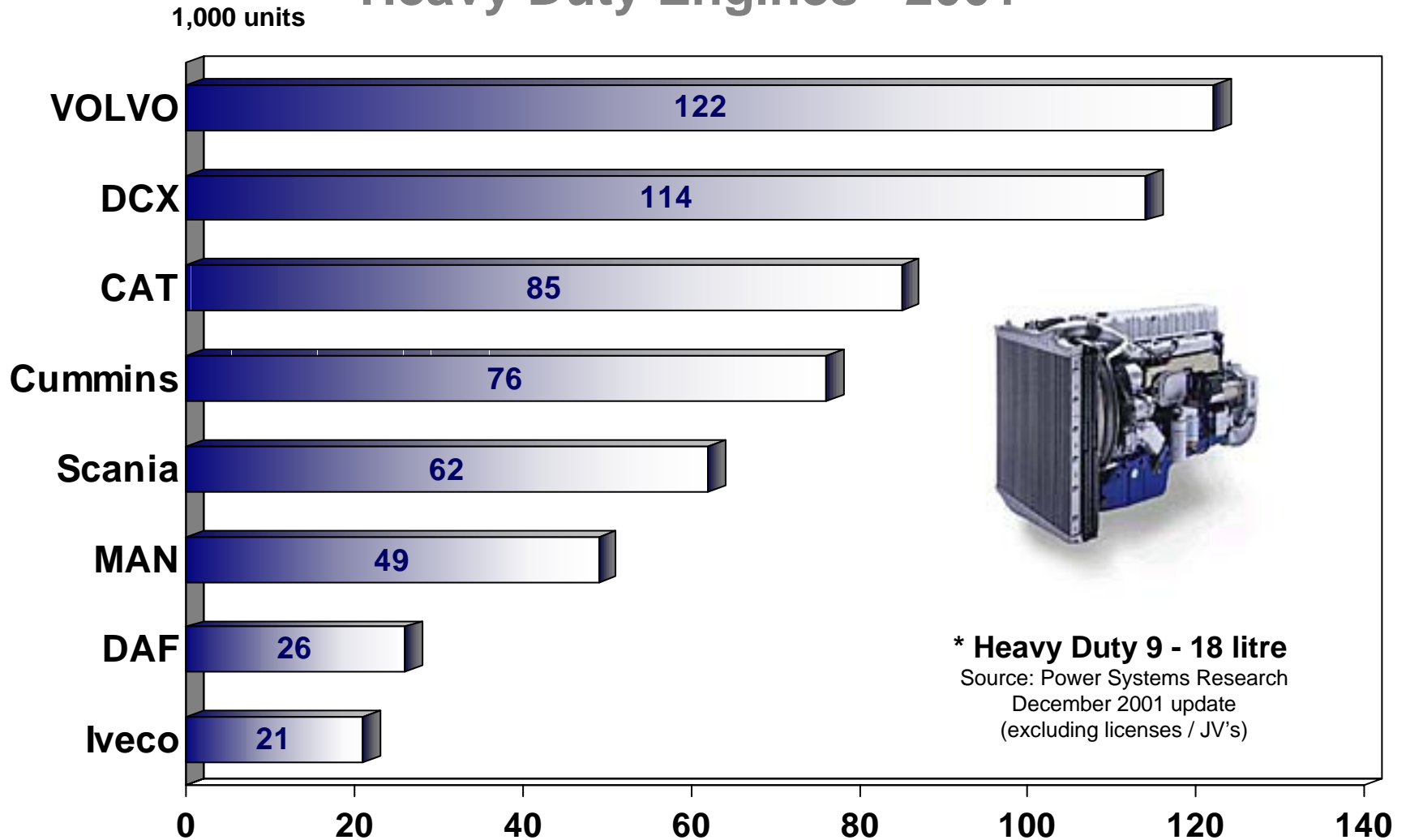

MD/ HD Engine Consolidation

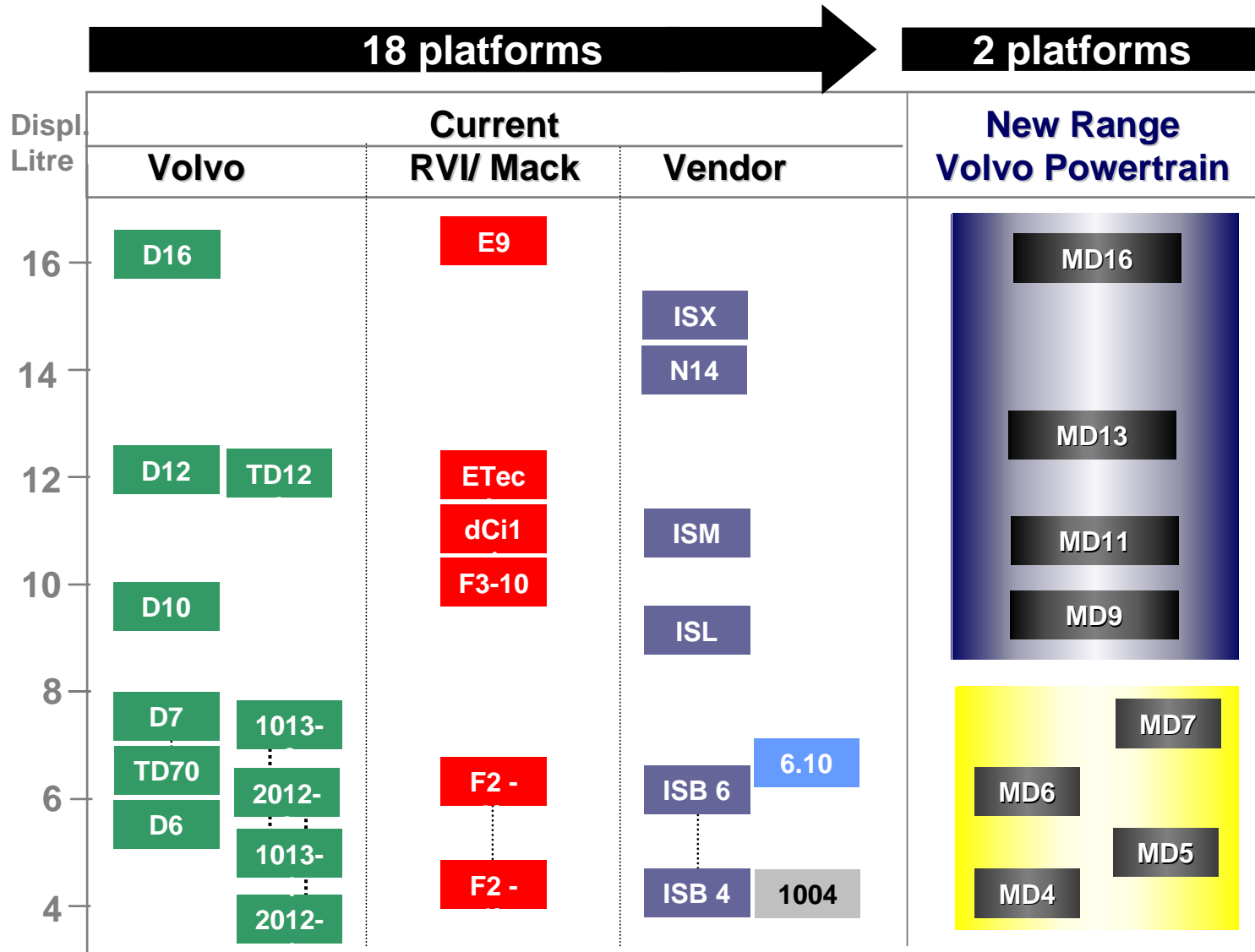

Shared Vehicle Architecture

Standardized Chassis & Components

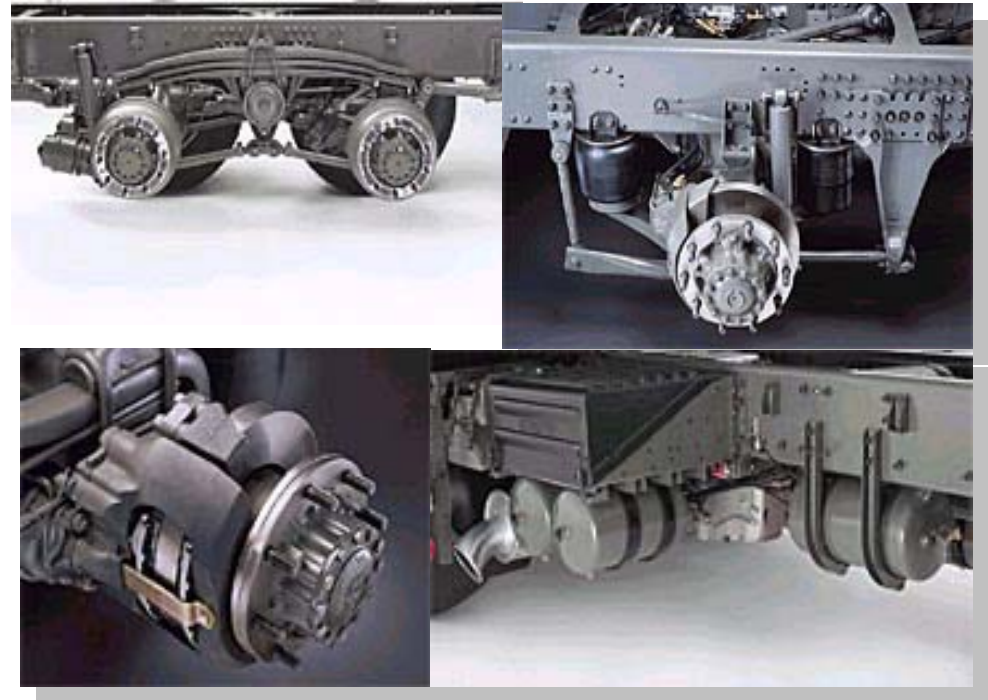
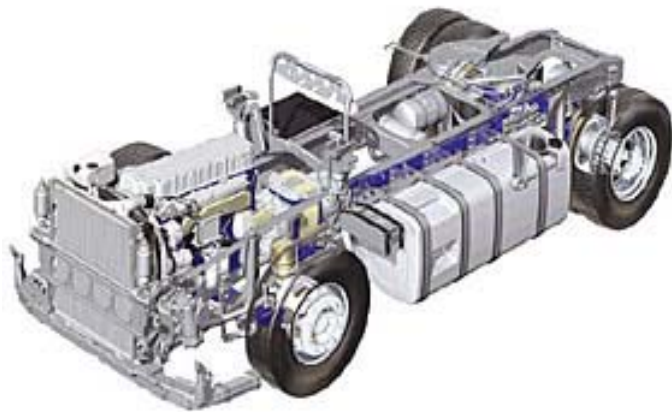

Two Years of Truck Integration



- Consolidation of diesel engine program
- Sharing of vehicle architecture
- Brand strategy in place
- Purchasing gains
- Expansion of Customer Finance
- Industrial restructuring
- Dealer optimization in North America

Volvo Construction Equipment

Towards a Full Liner



Articulated Hauler



Wheel Loader



Excavator



Motor Grader



Compact Wheel Loader



Skidsteer Loader



Compaction



Compact Excavator



Backhoe Loader



Telescopic Handler

Market Construction Equipment by Region

General Purpose Equipment 1997 - 2003F

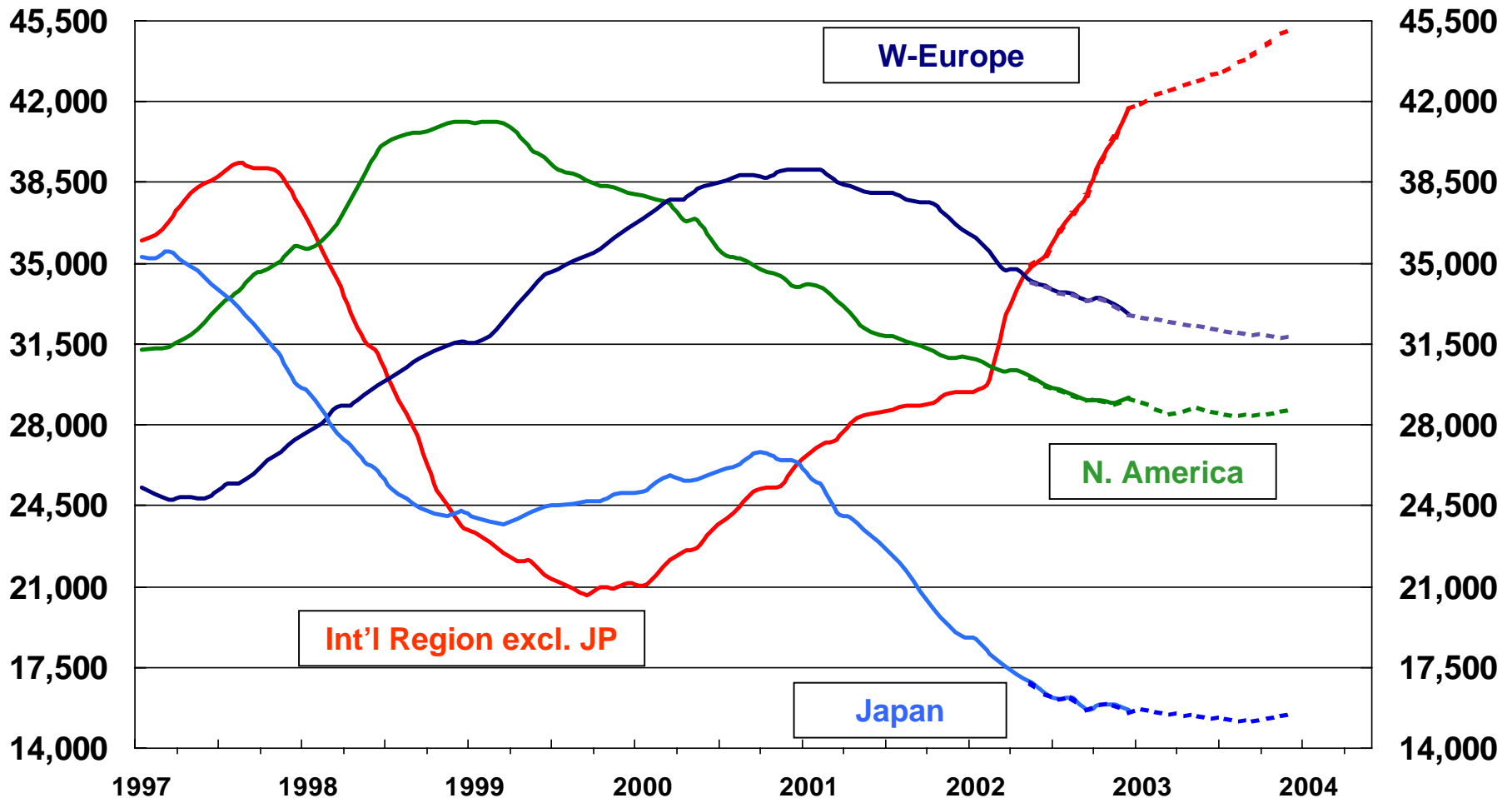

HQ Staff Fcst

12 month moving rates December 2002

Volvo Buses



Restructuring Actions

- Exit City Bus segment in the US
 - Closed two plants
- Production move to Poland
- Well positioned in important markets:
 - J/V's in China
 - Mexico

Volvo Aero

Manufacturing of Engine Component

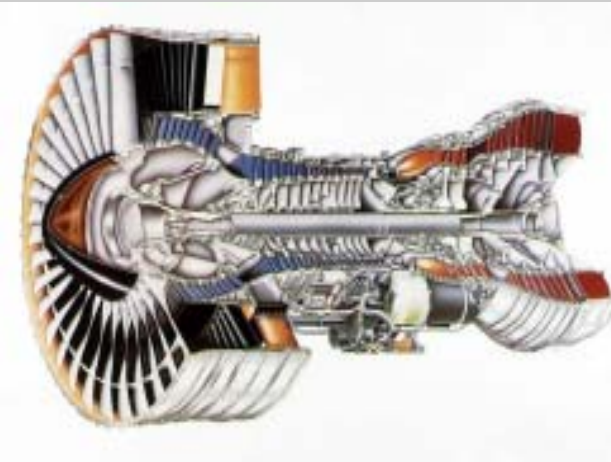

**Aerospace
Components**

**Land and
Marine
Gas Turbines**

44%

After Market



**Engine
Services**

**Aviation
Services**

49%

Military Segment



Volvo Penta



KAD300



TAD1032GE

Safety
Service
Alarm



Sea-Key



Volvo Financial Services



- Continued growth in Mack, Renault Trucks, Construction Equipment and Buses
- US Truck portfolio continues to stabilize
- Q4 2002: Sixth quarter in a row with improving operating income

In Focus: Controlled portfolio and profitability growth

Cash Flow Development

Fourth Quarter 2002

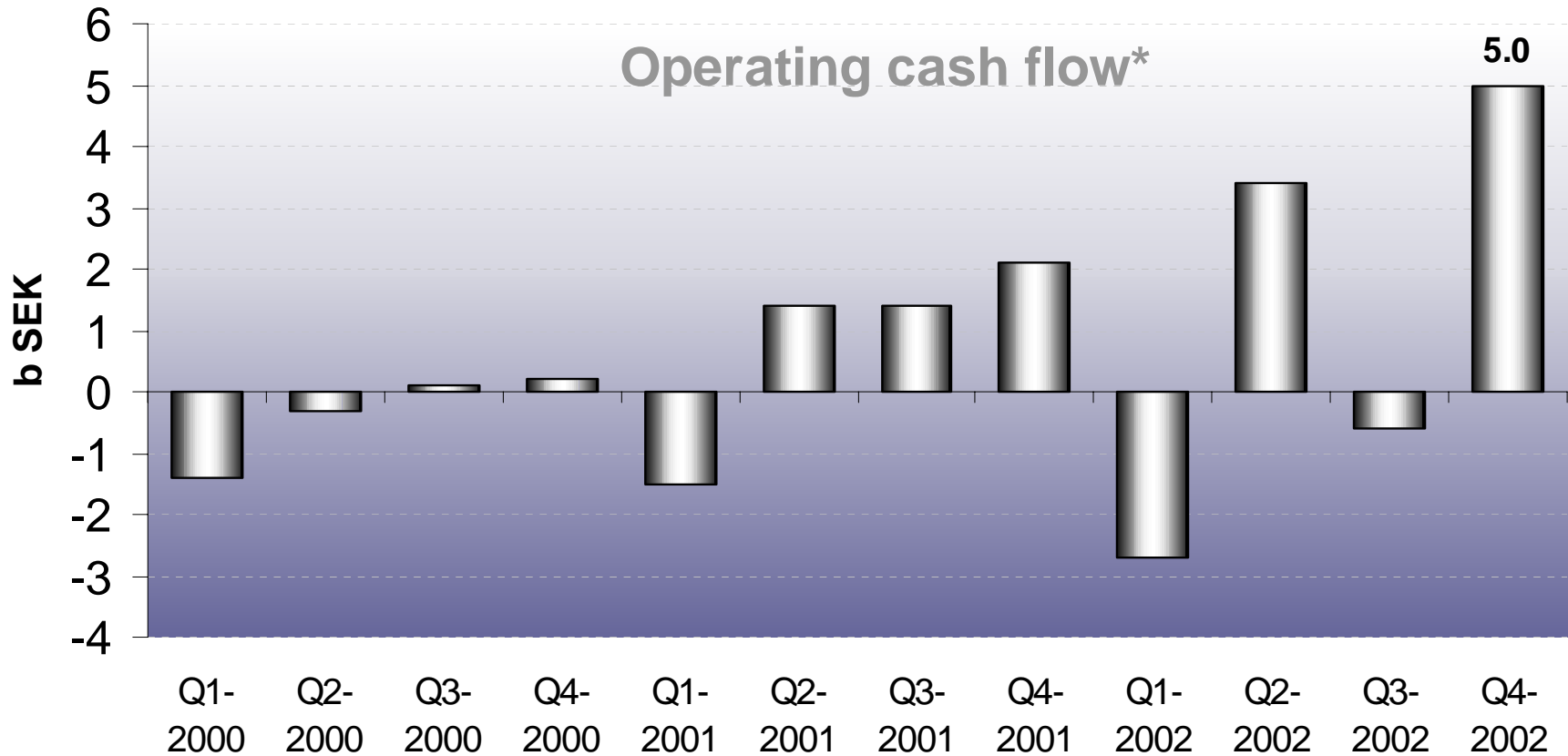

* Cash-flow after net investments excluding: Investments in shares, acquired & divested operations and Financial Services

Summary

Fourth Quarter and Full Year

- Strengthening the N. American Truck business
- Successful Volvo VN launch – 8000 orders
- Provisions in Volvo CE for dealer restructuring in North America
- Positive trend in Volvo Buses
- Strong positive Cash Flow

In Focus Going Forward

- Business Cycle Management
- Cash flow
- Continued truck integration
- Capitalize on the strong product portfolio

VOLVO

Lars I Persson

Corporate Finance

Lisbon March 12, 2003

Volvo Group

Financial Management

- Background:** - Established 1995 when Volvo re-focused to automotive
- Objective:** - Financial *stability* and *flexibility* throughout the *business cycle*
- Steering Principles:** - Key Financial Ratios
- Cash/Sales
 - Committed LT Facilities / Sales
 - L-t debt + equity + min. int/Fixed assets
- Policy
- Funding and lending should be in local currency (no currency exposure)
 - I/R exposure: Short-term benchmark
- Execution:**
- Volvo Treasury responsible for managing the interest net
 - Volvo Treasury has the global funding responsibility
 - Debt management separated into *Industrial & Commercial* and *Customer Finance*

Industrial & Commercial

Maturity structure

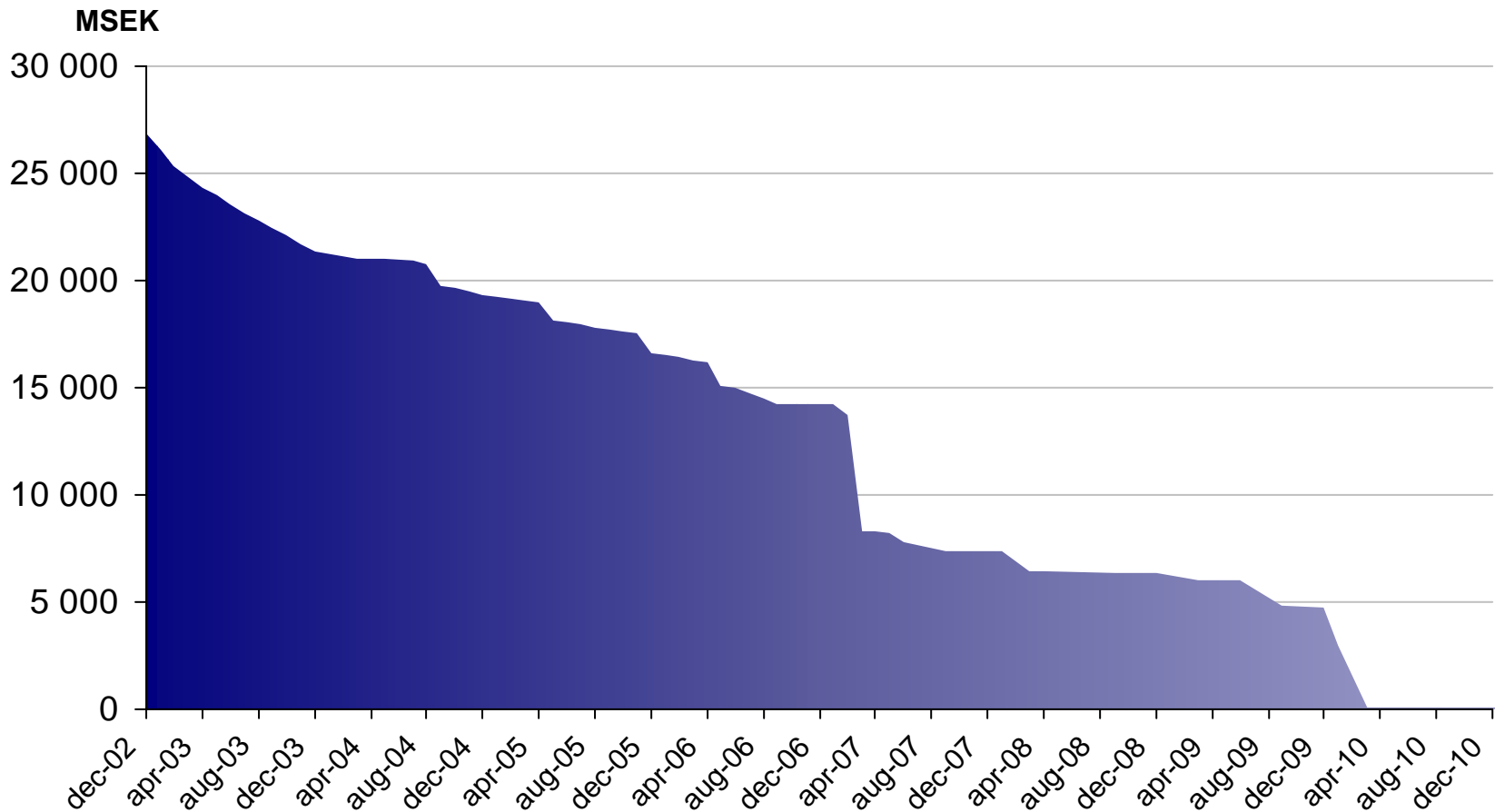

Customer Finance

Maturity structure

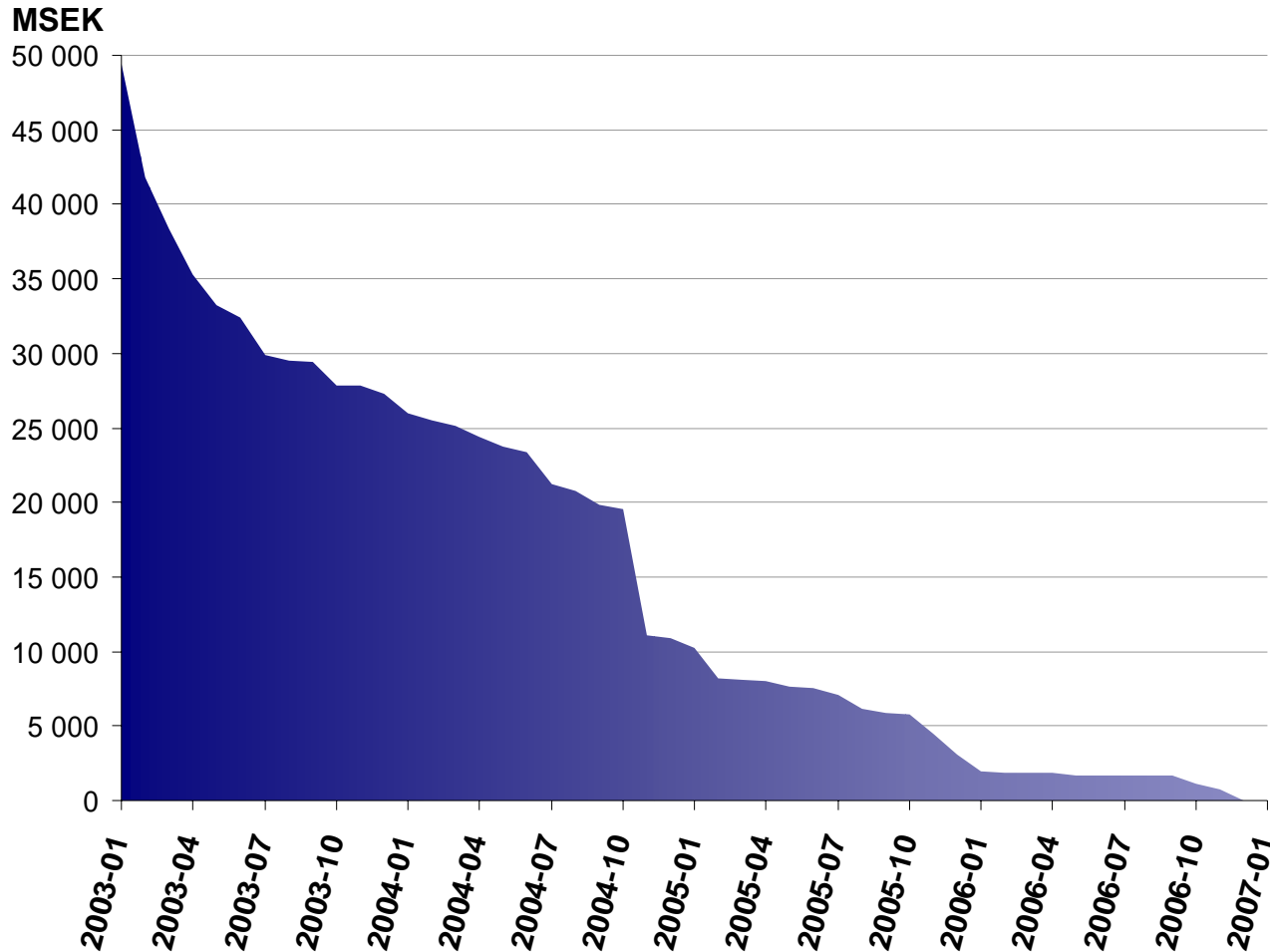

Actual 02Q4:

- Liquidity Matching 99%
- IR Matching 99%
- Currency Matching 100%

Volvo Group

Funding Sources

	"Max" Nom Amount	Used M Dec-02
	MSEK	MSEK
Commercial Paper	36 030	8 951
Medium Term Notes	44 689	26 904
Bonds	20 238	18 049
Term Loans	11 103	11 055
Uncommitted Facilities (ST Loans)	3 572	927
	115 632	65 886
Non VT Funding	7 538	7 538
TOTAL	123 170	73 424

Volvo Group

Committed Facilities

Maturity Structure

MSEK

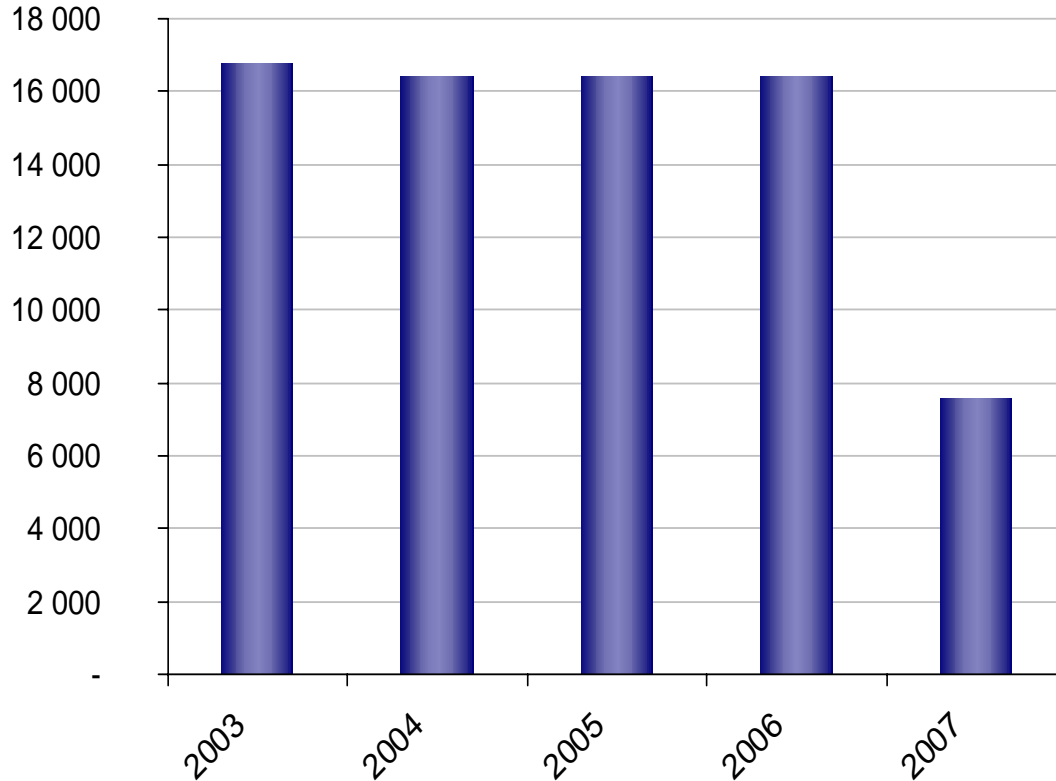

Syndicated Loan Facilities

- 1 000 MUSD 5y renegotiated 2001
- 850 MUSD 5y renegotiated June 2002
- No financial covenants or rating triggers in the documentation
- Strong Core Bank Group

Volvo Group

Credit Ratings March-2003

	<u>Long Term</u>	<u>Short Term</u>
- MOODY'S	Unsolicited A3 (Negative outlook)	P-2 (Stable)
- S&P		A2 (Stable)
- FITCH		Unsolicited F2
- DBRS	A (low) Negative outlook	R-1 (low) (Stable)
- R&I	A	(Not published!)

Commercial Paper Programs
(SEK, USD, EUR, CDN, AUD) ~ 36 bln SEK

Medium Term Notes
(SEK, EUR) ~ 44 bln SEK

A superior rating is prestigious and helps to attract good business partners and skillful people - in addition to the lower cost of funding.

Volvo Group (excl. Customer Finance)

Cash Conversion Cycle

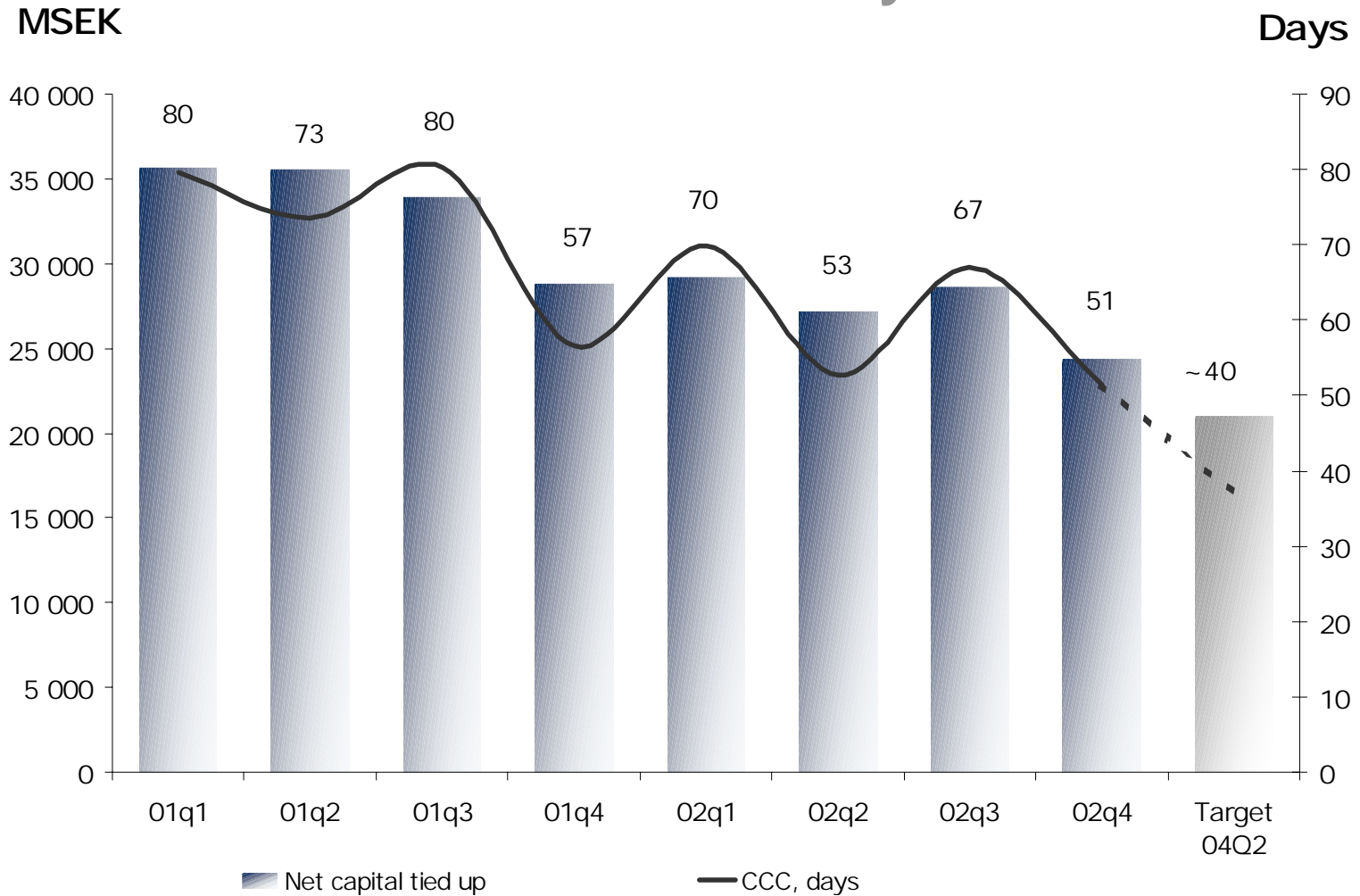

VOLVO

